

R 5

Rotary Vane Vacuum Pump RA 0155 A



Higher energy efficiency, more flow

using less horsepower – that's the principle behind the R 5 0155 A. With an innovative and enhanced design, the R 5 0155 A delivers the proven R 5 series benefits along with new energy efficiency improvements.

Short evacuation times

With the highest capacity in its class, the R 5 0155 A provides the shortest evacuation times. It also delivers all of the unique advantages that have set the R 5 series apart for years including excellent quality and operational reliability.

The R 5 0155 A is ideal for applications in the rough vacuum range and is designed to provide continuous operation from atmospheric pressure down to its ultimate pressure. This wide operating range is ensured by having ideal oil separation through the use of specially-developed Busch exhaust filters and industry-leading fiberglass vane materials.

Minimal maintenance

All R 5 series vacuum pumps require minimal maintenance that can be performed easily by the operator. Simply change the pump oil and filters at specified routine intervals. No additional maintenance is required.

R 5 rotary vane vacuum pumps provide economical and efficient vacuum generation in almost all industrial markets – whether for intermittent duty or around the clock. You can rely on the R 5.

R 5 special versions are available for applications such as pumping very wet gases or fumes or for extraction of oxygen or other explosive gases.



**R 5 – Proven and reliable.
Over 2.5 million pumps
in operation worldwide.**



R 5

Rotary Vane Vacuum Pump RA 0155 A



Technical specifications

Simplicity of design, operational reliability and high quality are all key features of the rotary vane principle. These vacuum pumps provide a high level of performance due to the selection of well-coordinated materials and components combined with precise machining and state-of-the-art manufacturing. Consistent performance is achieved across the entire vacuum region because of the integral, fully recirculating oil system. The highly efficient oil separation system ensures the cleanest exhaust air possible through the use of a multi-stage separation system that is standard with all R 5 vacuum pumps.

All R 5 0155 A vacuum pumps are of a close-coupled design, direct driven by TEFC motors. In addition, each pump is equipped standard with an inlet anti-suckback valve assembly to prevent backwards rotation at shut down. An optional gas ballast valve is available for pumping high vapor loads.

Accessories / Technical options

- Gas ballast valve
- Inlet filter
- Exhaust-back pressure gauge
- Oil level switch
- Temperature switch
- Vacuum pump oils for many applications

R 5 RA 0155 A

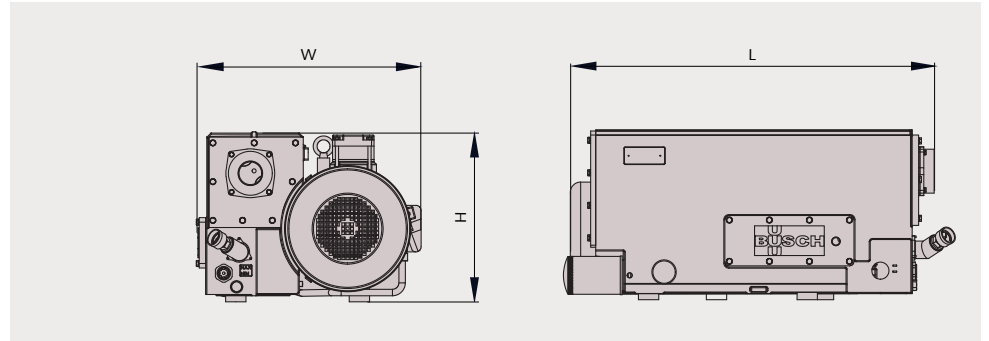

Pumping speed Air at 70 °F. Tolerance: ± 10%

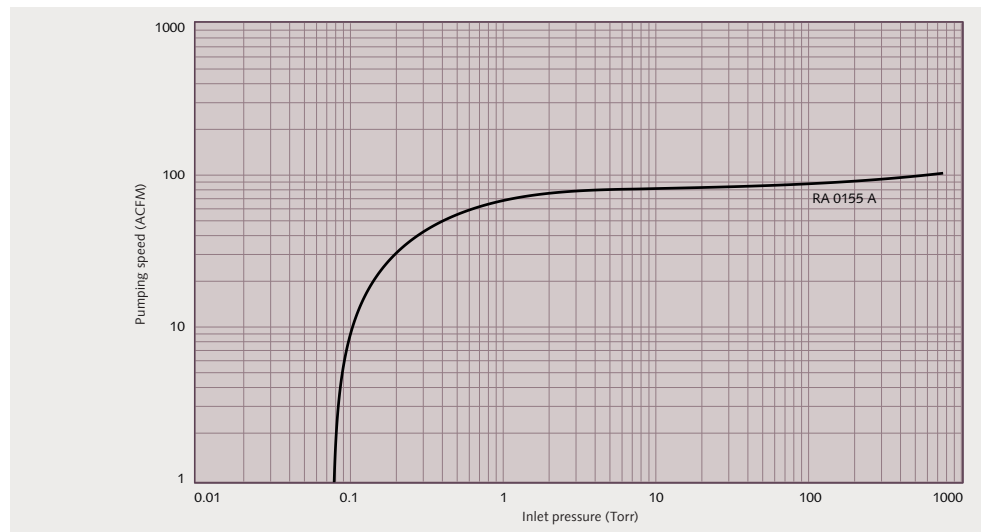

Technical Data		RA 0155 A
Max. pumping speed	ACFM	103
Ultimate pressure	Torr	0.075
Nominal motor rating	HP	5
Nominal motor speed	RPM	1800
Sound level (ISO 2151)	dB(A)	72
Oil capacity	Qts.	3.7
Approximate weight	Lbs.	362
Dimensions (L x W x H)	inches	35 1/4 x 21 3/4 x 16 3/8
Gas inlet / outlet		G 2" / G 2"

All performance data is based on ambient conditions of 14.7 PSIA and 70 °F, and has a tolerance of ± 10%.

Busch LLC

516 Viking Drive | Virginia Beach, VA 23452 | Phone 757-463-7800 | info@buschusa.com | www.buschusa.com

Argentina Australia België Brasil Canada Česko Chile 中國 Colombia Danmark Deutschland España France भारत गणराज्य Ireland ישראל Italia 日本 대한민국 Magyarország Malaysia México Nederland New Zealand Norge Österreich Perú Polska Portugal România Россия Schweiz Singapore South Africa Suomi Sverige 台灣 ประเทศไทย Türkiye الإمارات العربية المتحدة United Kingdom USA

Technical data is subject to change. Created in Germany. MG PL R5RA0155A USenus 12/2016 3.1